

RC5102

Dual Adjustable Voltage Regulators

Features

- 0.5% Setpoint Accuracy
- Both outputs adjustable from 1.5V to 3.6V
- 100mA output drivers for high current loads
- Short circuit protection
- Fast transient response
- Low I_{cc} current < 1mA
- Factory trimmed low TC voltage reference
- Drives N-Channel MOSFET, NPN or Darlington Pair
- 8 Lead SOIC

Applications

- 3.3V, 2.8V dual power supply for Pentium® P55 Processor
- Switchable single/dual power supply for Pentium P54C/P55C flexible motherboard implementation
- 1.5V regulator for Pentium Pro GTL+ Bus
- Adjustable dual output power supply for high current loads

Description

The RC5102, in combination with low R_{ds,on} n-channel MOSFETs, provides a precision low-dropout dual voltage regulator for Pentium, Cyrix® and Power PC® CPUs. By using the 12V supply available within the motherboard of the PC, the RC5102 achieves the high V_{gs} drive voltage to minimize the R_{ds,on} of the MOSFET for low dropout applications. Earlier designs involving p-channel MOSFETs or pnp transistors are either too costly or provide inadequate drop-out voltages at the high current required. Using the RC5102, a linear conversion from 5V to 2.8V is achieved at load currents in excess of 7A, depending upon the pass element. The RC5102 incorporates a 50MHz operational amplifier in the control path, thus optimizing transient performance due to instantaneous load changes.. Wafer-level trimming is used to adjust the precision of the reference to a nominal accuracy of ±0.5%. Improved line regulation is achieved through the use of a bootstrapped architecture within the bandgap reference. Overcurrent protection is available through the use of an external sense resistor.

Preliminary Information

Block Diagram

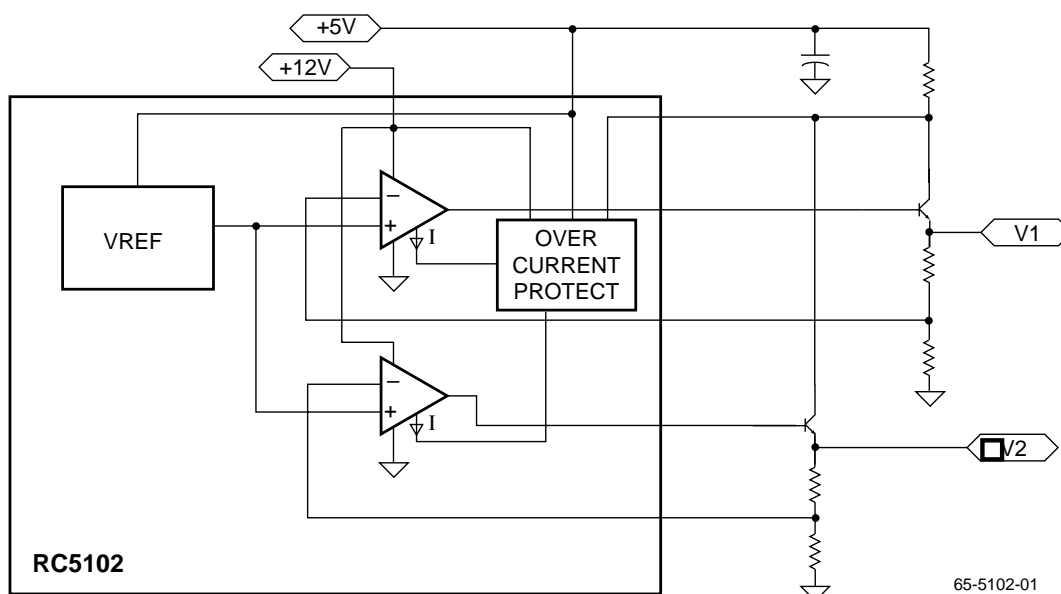

Rev. 0.9.1

Pin Assignments

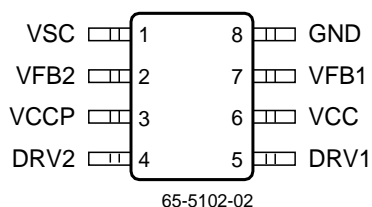

Pin Description

Pin Name	Pin Number	Pin Function Description
VSC	1	Over Current Protection Input
VFB2	2	Regulator 2 Voltage Feedback
VCCP	3	Output driver VCC; 12V nominal
DRV2	4	Regulator 2 Driver Output
DRV1	5	Regulator 1 Driver Output
VCC	6	Analog VCC; 5V nominal
VFB1	7	Regulator 1 Voltage Feedback
GND	8	Ground

Absolute Maximum Ratings¹

Parameter	Conditions	Min.	Typ.	Max.	Unit
VCCP	Driver Supply Voltage			13	V
VCC	Analog Supply Voltage			13	V
Ts	Storage Temperature	-65		150	°C
	Soldering Temperature	10 Seconds		300	°C

Note:

- Functional operation under any of these condition is not implied. Performance is guaranteed only if Operating Conditions are not exceeded.

Operating Conditions

(VCC = 5V, VCCP = +12V, TA = 25°C unless otherwise noted)

Parameter	Conditions	Min.	Typ.	Max.	Unit	
VCC	Analog Supply Voltage	4.75	5	10	V	
VCCP	Driver Supply Voltage	Minimum VCC + 3V	8	12	13	V
TA	Ambient Temperature	0		70	°C	

DC Electrical Characteristics

(VCC = 5V, VCCP = +12V, TA = 25°C unless otherwise noted)

Parameter	Conditions	Min.	Typ.	Max.	Unit
Vo	Output Voltage	TA = 0–70°C	1.5	3.6	V
Io	Output Drive Current	Each output	100		mA
Vref Acc	Setpoint Accuracy	IL = 1mA, Vout = 1.5V	0.5	1.2	%
VTC	Output Voltage TC	0 to 70 °C	-230		µV/°C
LDR	Load Regulation	0.5A to 7A	0.25		%Vo
LIR1	5V Line Regulation	VCC = 5V ± 5%, IL = 3.5A	12		mV/V
LIR2	12V Line Regulation	VCCP = 12V ± 10%, IL = 3.5A	19		mV/V
Vr	Output Noise	0.1 to 20KHz	30		µV
Vsc	Short Circuit trip	Rsense = 0.01Ω	100		mV
Pd	Power Dissipation	No Load	68		mW

AC Electrical Characteristics

(VCC = 5V, VCCP = +12V, TA = 25°C unless otherwise noted)

Parameter	Conditions	Min.	Typ.	Max.	Unit
Tr	Response Time	IL = 0.5A to 5.5A	5		µs
PSRR	Power Supply Rejection Ratio		65		dB

Application Schematics

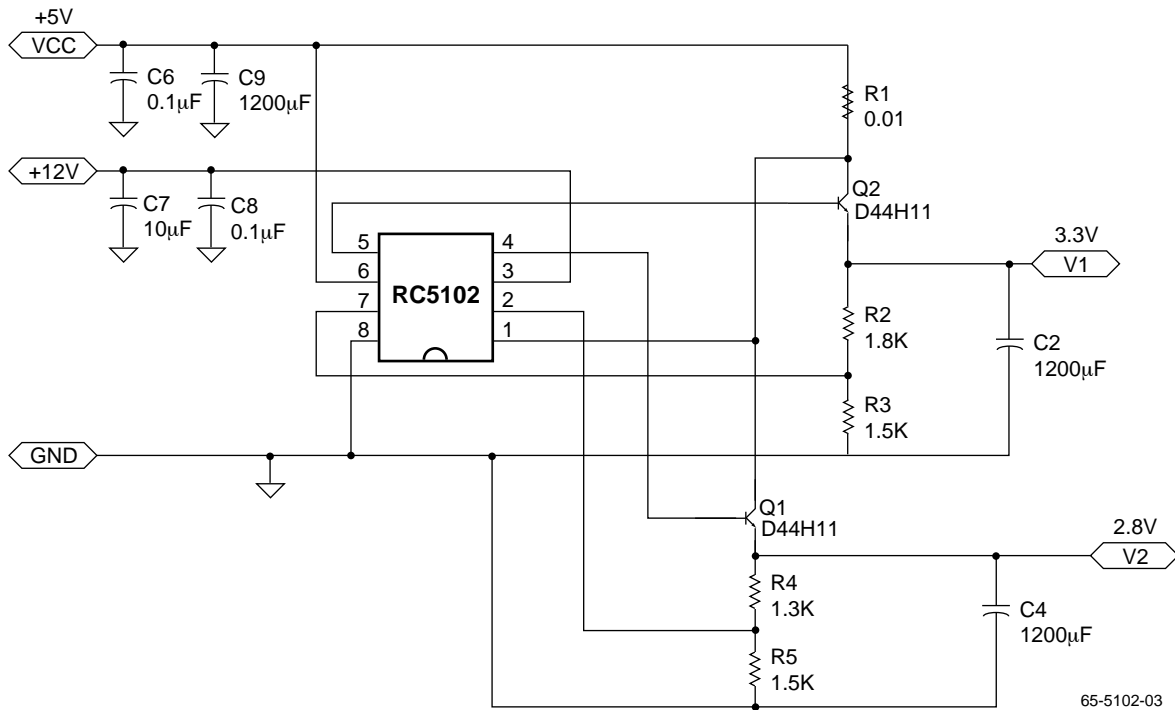

Figure 1. RC5102 Dual Output, 4A Application Schematic

Preliminary Information

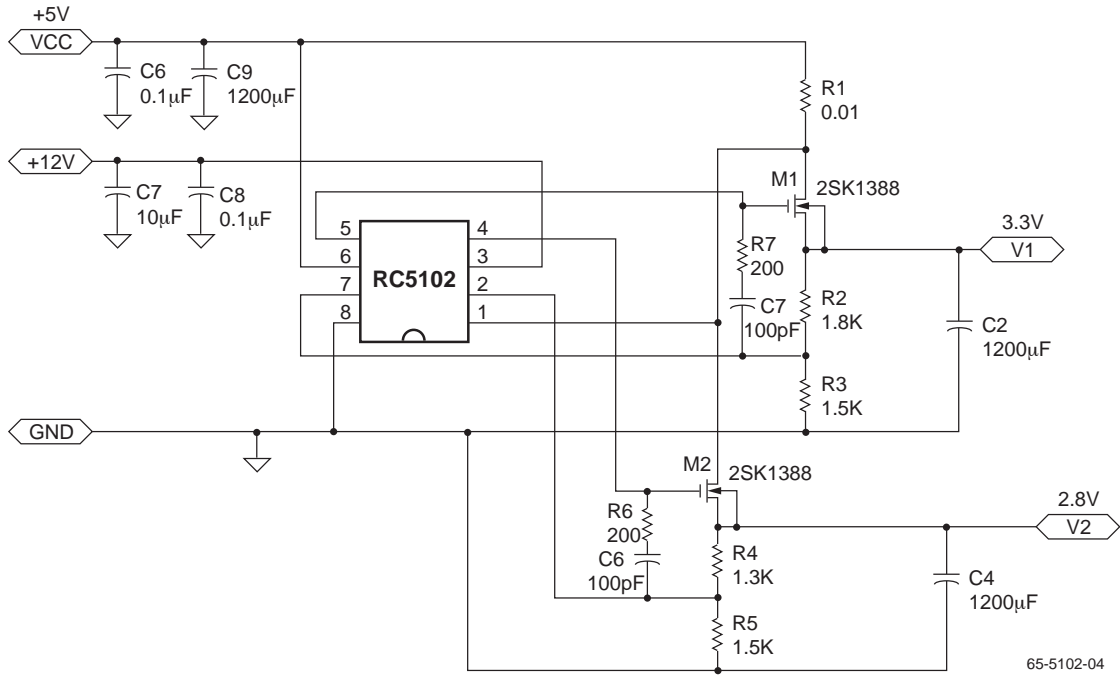

Figure 2. RC5102 Dual Output, 5A Application Schematic

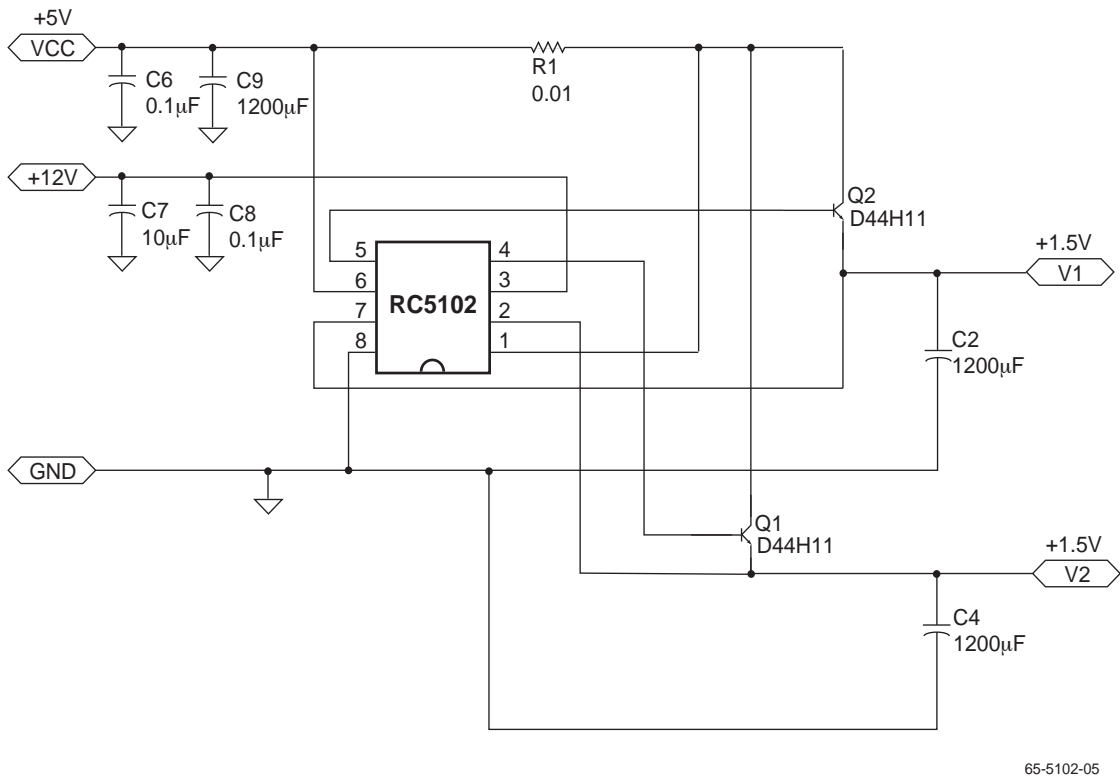

Figure 3. RC5102 Application Schematic for Pentium Pro GTL+ Bus Termination

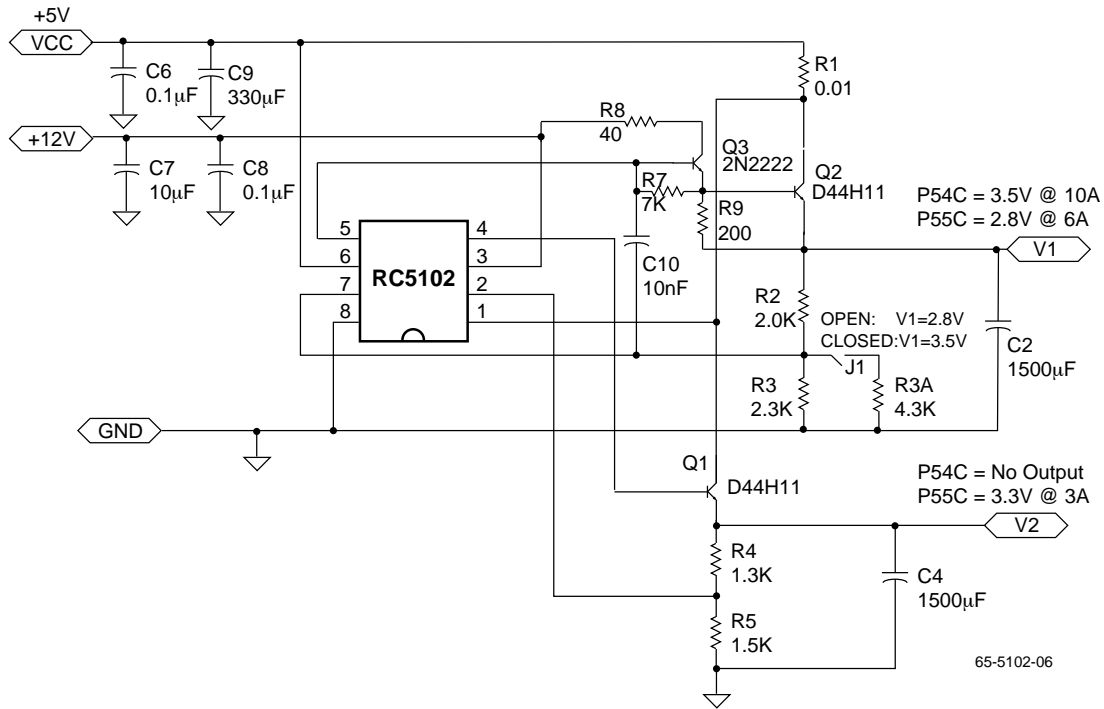

Figure 4. RC5102 Application Schematic for Pentium P54/P55C

Table 2. Components for P54C/P55C Application Circuit

Quantity	Reference	Part	Description
1	C9	330 µF	AVX Electrolytic
1	C7	1 µF	Chip Cap
2	C6, C8	0.1 µF	Chip Ceramic
2	Q1, Q2	D44H11	Power NPN Transistor
1	Q3	2N2222	General Purpose NPN Transistor
1	R1	0.01	1% Resistor
2	R5, R2	200	1% Resistor
1	R3	1.8 K	1% Resistor
1	R4	1.5 K	1% Resistor
1	R7	1.5 K	0.1% Resistor
1	R6	1.3 K	1% Resistor
1	R8	2.786 K	1% Resistor
1	R11	2 K	1% Resistor
1	R12	300 K	5% Resistor
1	R13	100 K	5% Resistor
1	R14	20 K	5% Resistor
2	C2, C4	1500 µF	Sanyo Electrolytic

Preliminary Information

Applications Information

Theory of Operation

The RC5102 is a dual output, low dropout voltage regulator controller intended for use in applications that require dual voltages at moderate to high output currents. Using external power transistors and precision trim resistors, a dual adjustable voltage regulator can be implemented. The choice of the component(s) will depend heavily upon the type of application. For load currents of up to 5A per output, the use of low-cost power NPN transistors is sufficient, as illustrated in figure 1. For applications requiring load currents greater than 5A, either an NPN darlington pair or an N-channel MOSFET is recommended due to the increased power throughput. Because the gate/base drive voltage is derived from the 12V input supply, the overall dropout voltage will depend only on the load current and either the $V_{ce,sat}$ of the NPN transistor or the R_{on} of the MOSFET. Therefore, very low dropout voltages can be achieved when the load currents are sufficiently low and a low R_{on} MOSFET or a low $V_{ce,sat}$ transistor is used.

In applications using N-channel MOSFETs, the external R-C network should be implemented as illustrated in figure 2. Failure to include this circuitry can result in an unstable gate drive signal. The actual component values may vary depending upon the individual application.

Minimum Load

The RC5102 regulator controller is specified over a finite load range. If the output current becomes too small, leakage currents will dominate and the output voltage(s) may drift out of regulation. Maintaining a minimum of 1mA load current on each output will assure that the load current will dominate any leakage currents over the operating temperature range.

Adjustable Output Voltage Design

The RC5102 allows each of the two outputs to be adjusted between the 1.5V reference voltage and 3.6V using two external precision resistors. In order to maintain the 1% output voltage accuracy, a minimum of 100uA should be fed back to the VFB1 and VFB2 pin to correctly bias the internal op-amp. For most applications, the sum value of the two resistors should not exceed approximately 35K Ω . For figures 1 and 2, the resistor values can be calculated using the following equations:

$$V_1 = V_{REF} \times \left(\frac{R_2 + R_3}{R_3} \right)$$

$$V_2 = V_{REF} \times \left(\frac{R_4 + R_5}{R_5} \right)$$

Output Capacitors

For stability and output noise reduction, the use of output capacitors is required. The required amount of load capacitance will depend upon the actual load current; higher loads will require larger capacitors. Regardless, an absolute minimum of 1uF is required to maintain stability under all load conditions. It is not necessary to use expensive low ESR type capacitors here; standard aluminum electrolytics are generally sufficient and can actually provide increased stability over extremely low ESR type devices. If possible, solid tantalum capacitors should be used in applications where transient response is critical.

Current Sense resistor

Over current protection is implemented using an external current sense resistor between the 5V input and the VSC pin that feeds the collector/drain of the pass transistors. This resistor will need to carry currents in excess of the sum of the two loads in order to perform correctly. The RC5102 will begin to limit the output current to the load(s) by turning off the output driver when the voltage across the sense resistor exceeds the nominal 100mV threshold. When this happens, the output voltage will temporarily go out of regulation. As the voltage across the resistor increases, the switch will continue to turn off until the current limit value is reached. At this point, the RC5102 will continuously deliver the limit current at a reduced output voltage level. To insure that load transient conditions do not momentarily cause deregulation of the output voltage, a 20% margin in the limit voltage is recommended. Thus the current sense resistor should be determined by the relationship:

$$R = 100\text{mV}/I_{\text{peak}},$$

$$\text{Where } I_{\text{peak}} = I_{\text{max}} \cdot 1.2$$

Since the value of the sense resistor is generally in the 10m Ω region, care should be taken in the layout of the PCB. Trace resistance can contribute significant errors. The traces to the VCC and VSC pins of the RC5102 should be Kelvin connected to the outside pads of the sense resistor.

Dual Power Supply Application

Some CPU power applications such as the Intel Pentium® P55C will require separate voltages for the CPU core and I/O circuitry. The circuit illustrated in figure 2 addresses this requirement using a minimum of external components. In this configuration, both linear regulator outputs can be easily programmed between 1.5V and 3.6V to meet a variety of dual voltage requirements. For loads of 4A or lower, the power dissipation of the external MOSFET should not pose any thermal design problems if it is chosen wisely. For loads greater than 10W, an appropriate heatsink must be chosen to assure the pass transistor remains within its Safe Operating Area for the desired output current level.

Auto Switching Single/Dual Power Supply for a Flexible Motherboard Design

A detailed analysis of the new Pentium-class processors reveals the requirement for an open-ended motherboard power supply design that can accommodate different CPUs in a single system. As an example, consider the Intel® P54C and P55C Pentium® processors. Although these two processors may occupy the same CPU socket, distinct differences exist in their power supply requirements. The present generation P54C uses a single supply for both the processor core and the I/O. For the higher performance devices, the supply voltage required is $3.5V \pm 100mV$ (VRE s-specification). For the lower performance models, a $3.3V \pm 5\%$ supply is acceptable. For improved compatibility, Intel has now re-specified its 3.3V standard CPUs for operation at the new 3.5V VRE level. The P55C multimedia upgrade processor, due to be released in the latter part of 1996, requires separate voltages for the core and I/O circuitry. The nominal core voltage is currently $2.8V \pm 100mV$, while the I/O supply remains at a nominal 3.3V. It is therefore desirable to implement a power supply design that will automatically detect the CPU model present and program each output voltage accordingly. The circuit in figure 4 directly addresses this requirement. The basic theory of this design is to provide an automatic switch between a single and a dual linear power supply depending upon which CPU occupies the socket.

To ease the task of identifying the CPU, the P55C processor includes a single-bit identification pin *VCC2DET*, at location AL1, to distinguish itself from the standard Pentium® P54C processor. This pin is always bonded to ground on the P55C CPU, while it is an internal no connect on the P54C. Therefore, the user can easily identify which processor occupies the CPU socket by direct monitoring of this pin. The circuit in figure 4 uses the CPU identification pin to select either a single or a dual output as well as select the appropriate output voltage for the CPU core power island.

Because the I/O circuitry can always operate from a nominal 3.5V supply, output 1 is set at a fixed 3.5V output. The CPU core supply is thus switched between 2.8V and 3.5V using an external FET and the appropriate resistor values. Using this circuit configuration, both outputs can source up to 5A. These current ranges will easily accommodate the standard Pentium® P54C and the P55C as well as other Pentium® compatible processors. For selected processors, the load currents required by each output will force the use of a MOSFET or Darlington pair as the pass elements. Using these higher-powered devices, the RC5102 can source up to 10A given the appropriate thermal requirements are also met. Please consult Raytheon Applications for additional details regarding CPU applications.

Current Sharing Option

If the RC5102 is to be used in an application that must address several CPUs, additional load current capability may be required from one of the outputs. For example, consider the Cyrix® 6x86 microprocessor. Although its specifications are very similar to those of the Intel Pentium® P54, it requires as much as 10A under worst-case conditions. To remedy this situation without adding additional costly pass elements, the RC5102 can be configured to allow both outputs to share the load current. In order to achieve acceptable performance, the layout of the output traces must be carefully routed. If the traces from the emitter of the pass transistors to the point where the two outputs are joined together, both outputs will share the load current equally. If the series impedances of each trace are different however, one output will tend to provide more than 50% of the load current while the other output will not be heavily burdened.

Using this option, low cost NPN transistors may be used instead of MOSFETs to deliver up to 10A loads. Again, the overall power limitation will depend heavily upon the level of thermal management for the pass elements. Please consult Raytheon Applications for additional details on this and other possible configurations using the RC5102.

Notes:

Preliminary Information

Preliminary Information

Notes:

Notes:

Preliminary Information

Mechanical Dimensions – 8 Lead SOIC

Symbol	Inches		Millimeters		Notes
	Min.	Max.	Min.	Max.	
A	.053	.069	1.35	1.75	
A1	.004	.010	0.10	0.25	
B	.013	.020	0.33	0.51	
C	.008	.010	0.20	0.25	5
D	.189	.197	4.80	5.00	2
E	.150	.158	3.81	4.01	2
e	.050 BSC		1.27 BSC		
H	.228	.244	5.79	6.20	
h	.010	.020	0.25	0.50	
L	.016	.050	0.40	1.27	3
N	8		8		6
α	0°	8°	0°	8°	
ccc	—	.004	—	0.10	

Notes:

1. Dimensioning and tolerancing per ANSI Y14.5M-1982.
2. "D" and "E" do not include mold flash. Mold flash or protrusions shall not exceed .010 inch (0.25mm).
3. "L" is the length of terminal for soldering to a substrate.
4. Terminal numbers are shown for reference only.
5. "C" dimension does not include solder finish thickness.
6. Symbol "N" is the maximum number of terminals.

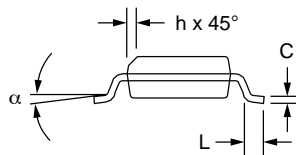
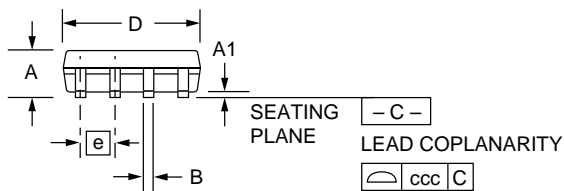
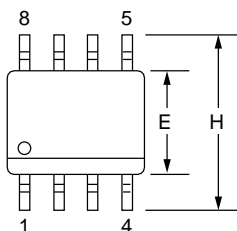

Preliminary Information

Ordering Information

Product Number	Package
RC5102M	8 pin SOIC

Preliminary Information

The information contained in this data sheet has been carefully compiled; however, it shall not by implication or otherwise become part of the terms and conditions of any subsequent sale. Raytheon's liability shall be determined solely by its standard terms and conditions of sale. No representation as to application or use or that the circuits are either licensed or free from patent infringement is intended or implied. Raytheon reserves the right to change the circuitry and any other data at any time without notice and assumes no liability for errors.

LIFE SUPPORT POLICY:

Raytheon's products are not designed for use in life support applications, wherein a failure or malfunction of the component can reasonably be expected to result in personal injury. The user of Raytheon components in life support applications assumes all risk of such use and indemnifies Raytheon Company against all damages.

Raytheon Electronics
Semiconductor Division
350 Ellis Street
Mountain View CA 94043
415 968 9211
FAX 415 966 7742